

Media Interface Technology

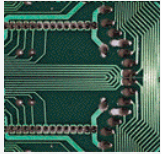

<http://www.mat.ucsb.edu/5940/>

Transistors

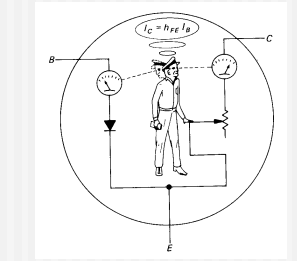
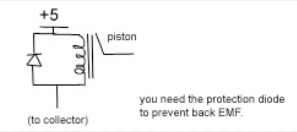
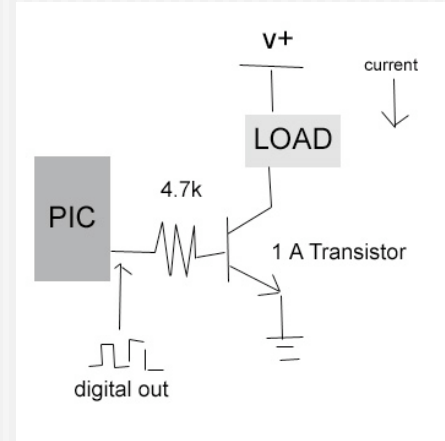

Transistors (cont)

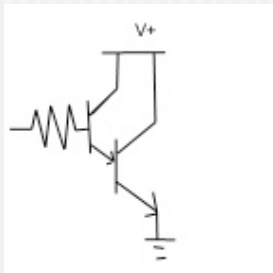

Darlington pair can be used if you need lots of current

Huge current gain (Beta squared)

Transistors (cont)

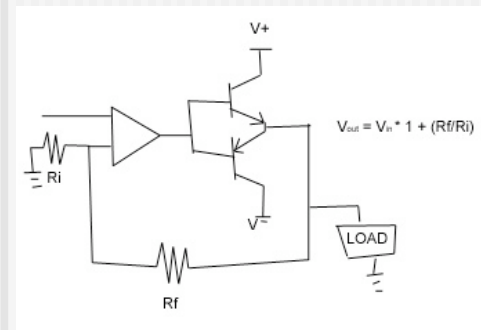

Push-Pull transistor pairs can source and sink current

This circuit allows a higher voltage to be controlled by a lower one.

Op-Amps

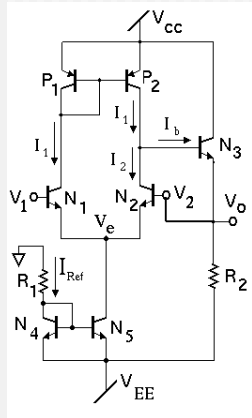
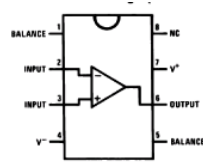

They've done all the hard work for you - making things simpler:

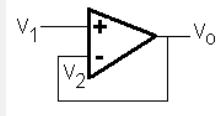

Here is an Op-Amp wired as a Unity gain buffer

Op-Amps (cont)

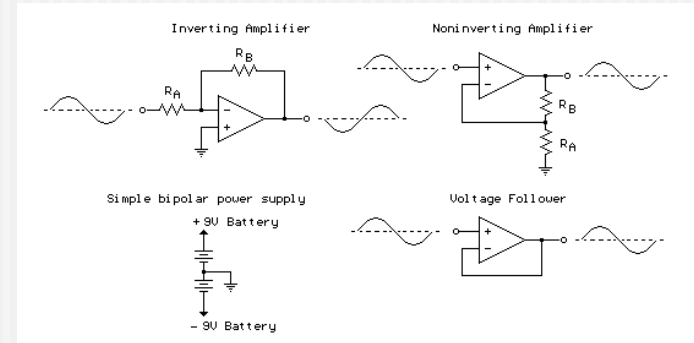

The Comparator

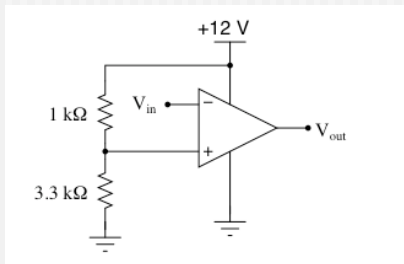

Makes an analog signal into a 1-bit digital signal

When V_{in} is above the threshold voltage formed by the voltage divider, The output is high - Otherwise it is low

The Schmitt Trigger

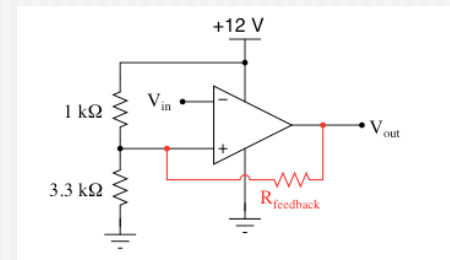

Suppresses jitter and spurious triggering from noisy signals (some sensors need this conditioning)

$R_{feedback}$ creates a "deadband" around the threshold voltage

The Differentiator / Integrator

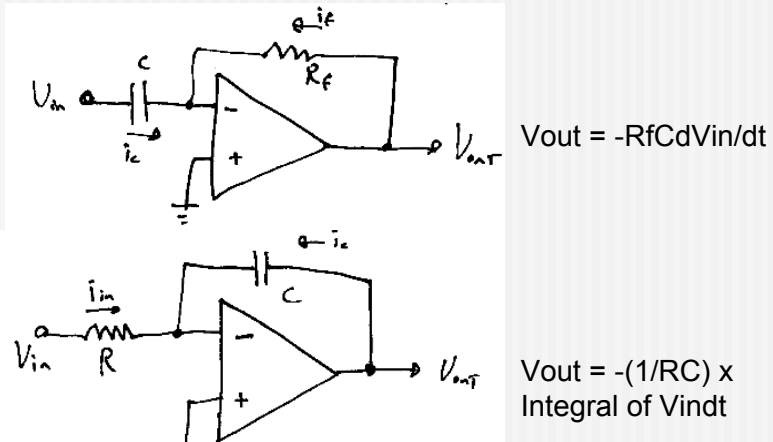

Simple Diode Pulse stretcher

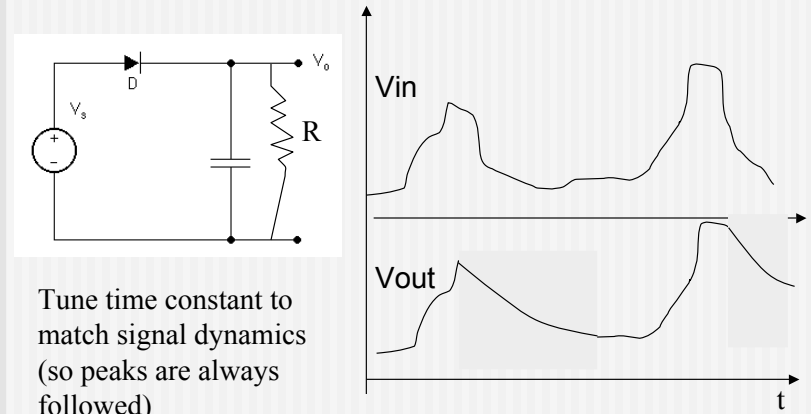

Questions?

Do we need to go over sampling theory?
(Nyquist theorem, etc...)

Assignment: build your CUI lab kit!

Guest lecture from Rama next Tuesday...